

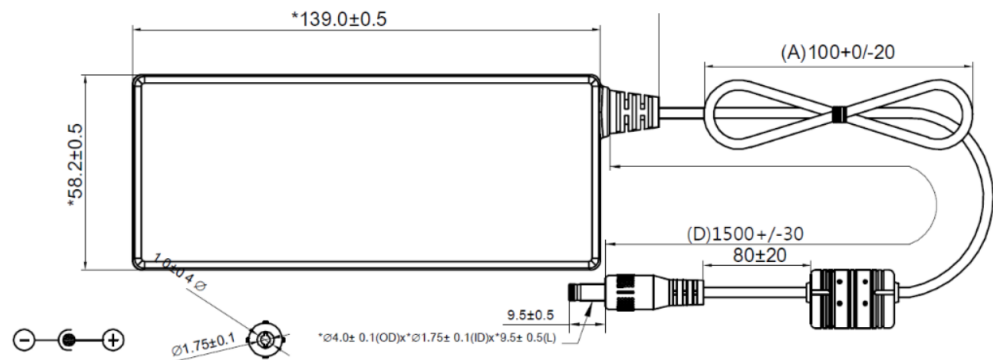

FUENTE DE ALIMENTACIÓN 90W PARA ONT PoE 4 PUERTOS ESTÁNDAR NEMA 5-15P / IEC C13

Descripción Fuente de alimentación 90W para conversión de corriente alternada (AC) para corriente continua (DC), para uso en modem óptico GPON PoE Furukawa de 4 puertos.

Imagen del producto



Compatibilidad

- MODEM OPTICO GPON FK-ONT-G400B/PoE S2 (cód 35510259)
- MODEM OPTICO GPON LW710-40BP (cód 35510464)

Características Generales

Potencia	90.0 W
Entrada	100 V - 240V
Salida	54 V 1,67 A @ 50 Hz / 60 Hz
Polarización de Salida	Externa "-" / Interna (+)
Temperatura de Operación	0 °C ~ +40 °C
Humedad de Operación	0 % ~ 90 % (non condensable)

Características Constructivas

- Dimensión (Ancho*Alto*Largo):
- 139 mm x 31 mm x 58 mm - Longitud del cable: 1,5m

EMI - La interferencia electromagnética	EMI STANDARDS	The power supply shall meet the radiated and conducted emission requirements for FCC part 15 CLASS B, EN55022 CLASS B, AS/NZS CISPR22 CLASS B. EN61000-3-2 CLASS D, EN61000-3-3. Remark: 6dBA margin minimum.
	EMS STANDARDS	<p>EN61000-4-2 Electrostatic Discharge (ESD) Static – discharge test by contact or air should be conducted with Static – discharge teeter, energy storage capacitance of 150pF, and discharge resistance of 330Ω. 15KV air discharge, 8KV contact discharge, Performance Criterion A</p> <p>EN61000-4-3 RADIATED ELECTROMAGNETIC FIELDS(RS) Radio- frequency Electromagnetic Field Susceptibility Test, RS, 80-1000MHz, 3V/m, 80%AM(1KHz), Performance Criterion A.</p> <p>EN61000-4-4 Electrical Fast Transient / Burst (EFT) Power Line to Line/Line to Earth: 1KV. Performance Criterion A.</p> <p>EN61000-4-5 Lightning Surge Attachment Lightning Surge voltage of differential and common modes shall be applied across AC input lines and across input and frame ground. Power Line to Line: 2.5KV. Line to Earth: 4 KV. Performance Criterion A.</p> <p>EN61000-4-6 CONDUCTED RADIO FREQUENCY DISTURBANCES(CS) Conducted Radio Frequency Disturbances Test, CS, 0.15-80 MHz, 3Vrms, 80%AM, 1KHz, Performance Criterion A.</p> <p>EN61000-4-8 POWER FREQUENCY MAGNETIC FIELD Power Frequency Magnetic Field Test, 50Hz, 3A/m. Performance Criterion A.</p> <p>EN61000-4-11 VOLTAGE DIPS/SHORT INTERRUPTION/VARIAIONS Voltage Dips, 30% reduction- 10ms, Performance Criterion B, 60%. Reduction – 100ms, Performance Criterion B, Voltage Interruptions>95%. Reduction - 5000ms, Performance Criterion B.</p>

Alimentación

- Power plug estándar NEMA 5-15P.

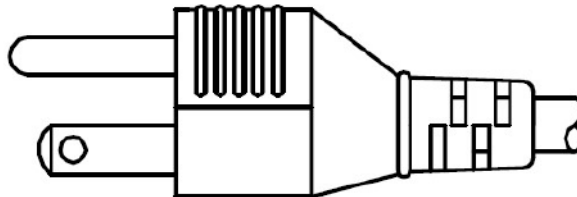
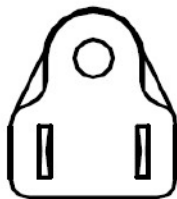

Certificaciones

- NOM

Garantía

- Garantía de 1 ano.

- Validez Técnica del Software: 365 días.

La cobertura de la garantía del producto y el servicio de soporte técnico están condicionados al uso exclusivo de equipos de la familia GPON Furukawa (OLTs, ONUs, Fuentes de Alimentación, Transceptores, ...).

[Codificación](#)